



Atex   II 2 GD*

* Available on request (up to 2")

* Auf Anfrage (bis 2")

DOUBLE ACTING / DOPPELTWIRKEND



art. D61AA20	F/F gas 1/4" - 2"
art. D61AA50	F/F NPT 1/4" - 2"
art. D61AA45	SW 1/4" - 2"
art. D61AA47	BW 1/4" - 2"

SINGLE ACTING / EINFACHWIRKEND



art. S61AA20	F/F gas 1/4" - 2"
art. S61AA50	F/F NPT 1/4" - 2"
art. S61AA45	SW 1/4" - 2"
art. S61AA47	BW 1/4" - 2"

ACTUATOR FEATURES:

- ROTATION ANGLE: 90°.
- TEMPERATURE LIMITS: -20°C / +90°C.
- MAXIMUM SUPPLY PRESSURE: 10 bar (8 bar for DNA045).
- NOMINAL PRESSURE: 5.62 bar.
- SUPPLY FLUID: filtered compressed air.
- LUBRICATION: NBR compatible oil to be used.

For further information on the actuator technical features refer to the specific data sheet for actuator at the end of this catalogue (page 348/349).

STANDARD VALVE FEATURES:

- TEMPERATURE LIMITS: -20°C / +150°C (PTFE)
use up to +180°C (PTFE+CRB).
- MAXIMUM WORKING PRESSURE: PN140 1/4" - 1"
PN100 1"1/4 - 2"
- CONNECTIONS: F/F Rp UNI ISO 7/1 (UNI EN 10226) DIN2999 parallel GAS.
F/F NPT
SW ANSI B16.11 socket weld
BW ANSI B16.25 butt weld sch40.

For general applications and special executions, see the manual valve.

ALLGEMEINE DATEN DES STELLANTRIEBS

- DREHWINKEL: 90°.
- TEMPERATURBEREICH: -20°C / +90°C.
- MAXIMALER FÖRDERDRUCK: 10 bar (8 bar für DNA045).
- NENNDRUCK: 5.62 bar.
- BETRIEBSMEDIUM: Druckluft, gefiltert.
- SCHMIERUNG: NBR-kompatibles Öl verwenden.

Für weitere Infos über die technischen Eigenschaften des Stellantriebs siehe diesbezügliche technische Beschreibung am Ende des Katalogs (S. 348/349).

ALLGEMEINE DATEN DER STANDARDABSPERRKLAPPE:

- TEMPERATURBEREICH: -20°C / +150°C (PTFE)
Anwendung bis +180°C (PTFE+CRB).
- MAX. BETRIEBSDRUCK: PN140 1/4" - 1"
PN100 1"1/4 - 2"
- ANSCHLÜSSE: F/F Rp UNI ISO 7/1 (UNI EN 10226) DIN 2999 zylinderförmig GAS.
F/F NPT
SW ANSI B16.11 mit Schweißmuffe
BW ANSI B16.25 mit Stumpfschweißen sch40.

Für allgemeine Eigenschaften sowie Sonderausführungen siehe Handventil.

DOUBLE ACTING / DOPPELTWIRKEND												
SIZE	WEIGHT g.	A	B	C	E	F	CH esag.	L	M	N	ACTUATOR	KIT
1/4"	1240	116	70	68	21	153	20.5	61	42	10.9	DNA045AZ00	K1GA0002
3/8"	1240	116	70	68	21	153	23.5	61	42	12.7	DNA045AZ00	K1GA0002
1/2"	1825	133	78	74	26	173.5	29.5	71	52	16	DGA052AX00	K1GA0304
3/4"	2475	133	78	74	30	178.5	35	81.5	59.5	19.6	DGA052AX00	K1GA0305
1"	4575	137	89	88	36	198.5	43	91.5	72	25	DGA063AX00	K1GA0406
1" 1/4	5675	137	89	88	40	202	53	114.5	79.5	32	DGA063AX00	K1GA0407
1" 1/2	7730	161	102	100	45	227	61	122	90	38.1	DGA075AX00	K1GA0408
2"	9985	180	108	108	50.5	243.5	76	142.7	101	50.8	DGA083AX00	K1GA0408

SINGLE ACTING / EINFACHWIRKEND												
SIZE	WEIGHT g.	A	B	C	E	F	CH esag.	L	M	N	ACTUATOR	KIT
1/4"	2320	137	89	88	21	183	20.5	61	42	10.9	SGA0634X00	K1GA0102
3/8"	2320	137	89	88	21	183	23.5	61	42	12.7	SGA0634X00	K1GA0102
1/2"	3345	161	102	100	26	199.5	29.5	71	52	16	SGA0754X00	K1GA0404
3/4"	3995	161	102	100	30	204.5	35	81.5	59.5	19.6	SGA0754X00	K1GA0405
1"	6135	180	108	108	36	218.5	43	91.5	72	25	SGA0834X00	K1GA0506
1" 1/4	7235	180	108	108	40	222	53	114.5	79.5	32	SGA0834X00	K1GA0507
1" 1/2	11600	222	120	140	45	267	61	122	90	38.1	SNA1104X00	K1GA0408
2"	13250	222	120	140	50.5	275.5	76	142.7	101	50.8	SNA1104X00	K1GA0408

SECTION / QUERSCHNITT

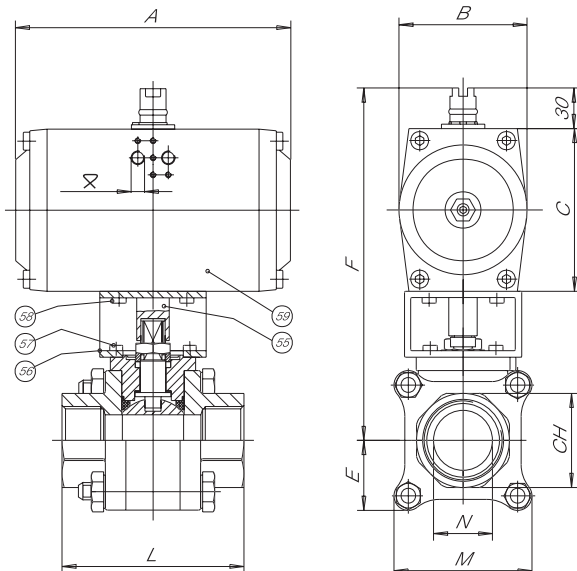

063÷092=1/8" G
110÷190=1/4" G

LIST OF VALVE COMPONENTS AND MATERIALS / TEILE- UND WERKSTOFFLISTE DES VENTILS

55	ACTUATOR PIN / WELLE FÜR STELLANTRIEB	1	C.S. ZINC.
56	BRACKET / BRÜCKE	1	C.S. ZINC.
57	BRACKET/VALVE SCREW / SCHRAUBE BRÜCKE/VENTIL	4	8.8 ZINC.
58	BRACKET/ACTUATOR SCREW / SCHRAUBE BRÜCKE/STELLANTRIEB	4	8.8 ZINC.
59	ACTUATOR / STELLANTRIEB	1	AL. ANODIZED