

MOON[®] STAINLESS STEEL WITH PNEUMATIC ACTUATOR MIT PNEUMATIKANTRIEB



Atex   II 2 GD*

* Available on request

* Auf Anfrage

DOUBLE ACTING / DOPPELTWIRKEND



art. D41AA	AISI 316 DN15 - DN100
art. D4DAA	AISI 316 ND DN40 - DN100
art. D81AA	AISI 304 DN15 - DN100

SINGLE ACTING / EINFACHWIRKEND



art. S41AA	AISI 316 DN15 - DN100
art. S4DAA	AISI 316 ND DN40 - DN100
art. S81AA	AISI 304 DN15 - DN100

ACTUATOR FEATURES:

- ROTATION ANGLE: 90°.
- TEMPERATURE LIMITS: -20°C / +90°C.
- SUPPLY MAXIMUM PRESSURE: 10 bar (8 bar for DNA045).
- NOMINAL PRESSURE: 5.62 bar.
- SUPPLY FLUID: filtered compressed air.
- LUBRICATION: NBR compatible oil to be used.

For further information on the actuator technical features refer to the specific data sheet for actuator at the end of this catalogue (page 348/349).

STANDARD VALVE FEATURES:

- STANDARDS: BS EN ISO 17292 : 2004, fire safe to BS6755-API 6 FA-API607.
- TEMPERATURE LIMITS: -20°C / +180°C. (PTFE).
- MAXIMUM WORKING PRESSURE: PN16.
- CONNECTIONS WITH FLANGES: UNI EN 1092 and DIN2501 BL.1.
- FLANGE DRILLING: metric.
- SPECIAL EXECUTIONS: ANSI150 - ANSI300 - PN40.

For general applications and special executions, see the manual valve.

ALLGEMEINE DATEN DES STELLANTRIEBS

- DREHWINKEL: 90°.
- TEMPERATURBEREICH: -20°C / +90°C.
- MAXIMALER FÖRDERDRUCK: 10 bar (8 bar für DNA045).
- NENNDRUCK: 5.62 bar.
- BETRIEBSMEDIUM: Druckluft, gefiltert.
- SCHMIERUNG: NBR-kompatibles Öl verwenden.

Für weitere Infos über die technischen Eigenschaften des Stellantriebs siehe diesbezügliche technische Beschreibung am Ende des Katalogs (S. 348/349).

ALLGEMEINE DATEN DER STANDARDABSPERRKLAFFE:

- ALLGEMEINE VORSCHRIFTEN: BS EN ISO 17292 : 2004, Fire Safe laut BS6755-API 6 FA-API607.
- TEMPERATURBEREICH: -20°C / +180°C. (PTFE).
- MAX. BETRIEBSDRUCK: PN16.
- ANSCHLÜSSE AUFFLANSCHBAR: UNI EN 1092 und DIN2501 BL.1.
- FLANSCHBOHRUNG: metrisch.
- SONDERAUSFÜHRUNGEN: ANSI150 - ANSI300 - PN40.

Für allgemeine Eigenschaften sowie Sonderausführungen siehe Handventil.

DOUBLE ACTING / DOPPELTWIRKEND													
SIZE	WEIGHT g.	A	B	C	E	F	G	I	L	LND	PN	ACTUATOR	KIT
DN15	1880	116	70	68	170	45	M12	65	35	35	40	DNA045AZ00	K1GA0004
DN20	2360	116	70	68	170	50	M12	75	38	38	40	DNA045AZ00	K1GA0004
DN25	3000	116	70	68	202	55	M12	85	43	43	40	DNA045AZ00	K1GA1006
DN32	4900	133	78	74	222	65	M16	100	54	54	40	DGA052AX00	K1GA0007
DN40	7100	137	89	88	238	70	M16	110	60	66	16	DGA063AX00	K1GA1008
DN50	9500	161	102	100	253	75	M16	125	70	83	16	DGA075AX00	K1GA0008
DN65	17900	182	108	108	294	87.5	M16	145	95	103	16	DGA083AX00	K1GA0010
DN80	23400	209	120	117	327	95	M16	160	122	122	16	DGA092AX00	K1GA0010
DN100	39100	294	120	140	378	110	M16	180	140	153	16	DNA118AX00	K1GA0012

SINGLE ACTING / EINFACHWIRKEND													
SIZE	WEIGHT g.	A	B	C	E	F	G	I	L	LND	PN	ACTUATOR	KIT
DN15	2000	116	70	68	180	45	M12	65	35	35	40	SNA0453Z00	K1GA0604
DN20	2800	133	78	74	190	50	M12	75	38	38	40	SGA0524X00	K1GA0005
DN25	4000	137	89	88	220	55	M12	85	43	43	40	SGA0634X00	K1GA0106
DN32	6300	161	102	100	240	65	M16	100	54	54	40	SGA0754X00	K1GA0107
DN40	7920	182	108	108	250	70	M16	110	60	66	16	SGA0834X00	K1GA0108
DN50	11170	209	120	117	265	75	M16	125	70	83	16	SGA0924X00	K1GA0108
DN65	23170	292	120	140	320	87.5	M16	145	95	103	16	SNA1184X00	K1GA0110
DN80	27940	294	120	140	340	95	M16	160	122	122	16	SNA1184X00	K1GA0011
DN100	42720	300	137	160	390	110	M16	180	140	153	16	SNA1274X00	K1GA0112

SECTION / QUERSCHNITT

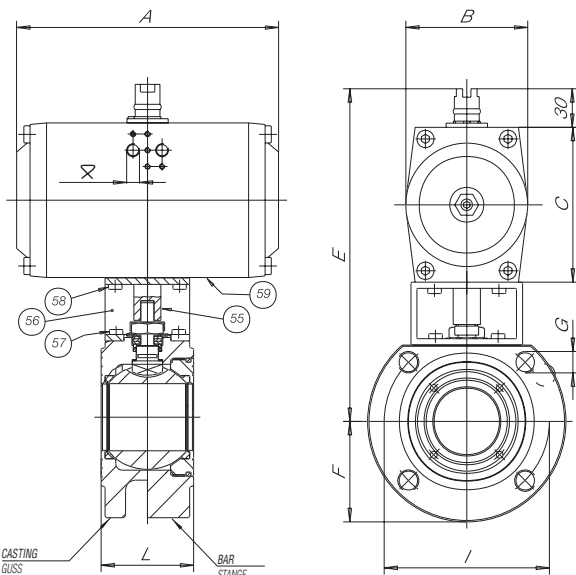

Ø 063±0.02=1/8" G
110±0.19=1/4" G

LIST OF VALVE COMPONENTS AND MATERIALS / TEILE- UND WERKSTOFFLISTE DES VENTILS

55	ACTUATOR PIN / WELLE FÜR STELLANTRIEB	1	C.S. ZINC.
56	BRACKET / BRÜCKE	1	C.S. ZINC.
57	BRACKET/VALVE SCREW / SCHRAUBE BRÜCKE/VENTIL	4	8.8 ZINC.
58	BRACKET/ACTUATOR SCREW / SCHRAUBE BRÜCKE/STELLANTRIEB	4	8.8 ZINC.
59	ACTUATOR / STELLANTRIEB	1	AL. ANODIZED