

MOON CR[®]

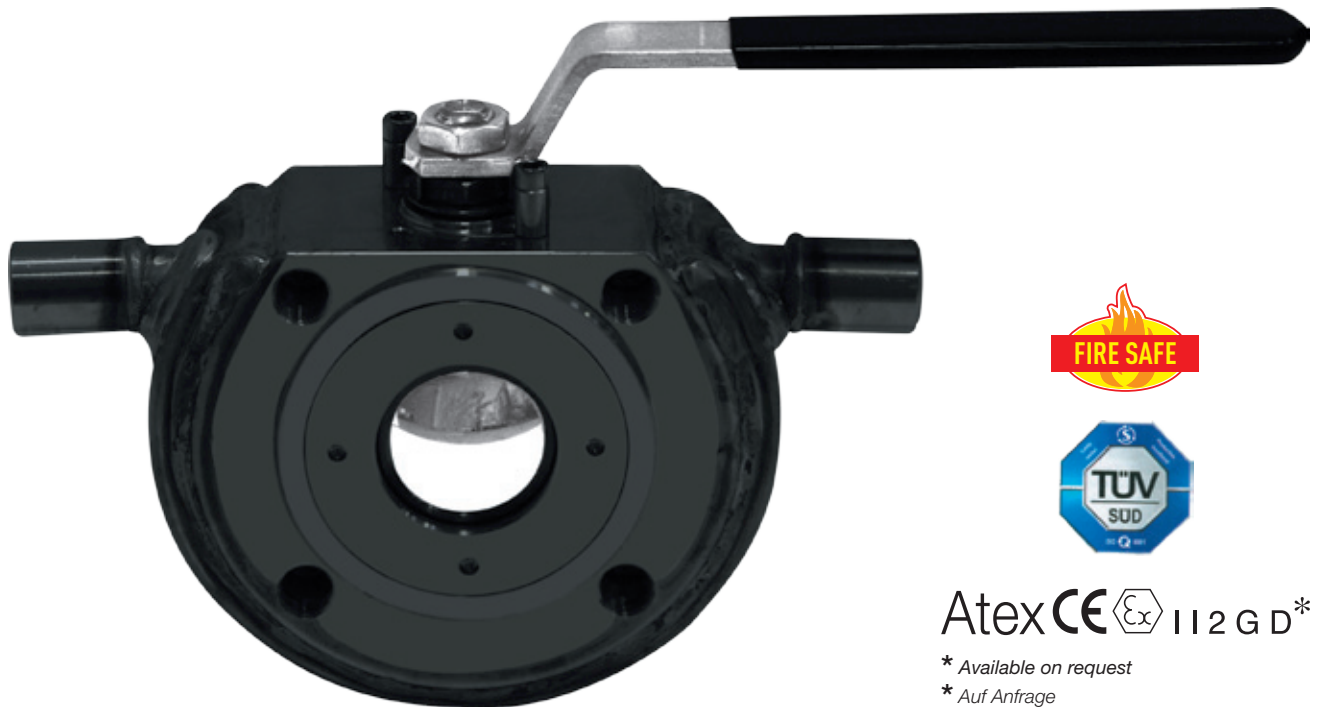

Atex CE Ex II 2 GD*

* Available on request

* Auf Anfrage

STAINLESS STEEL

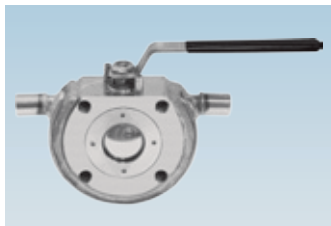

art. P2.....002	[Extension nipples / Stutzen 1/2"] MOON ND 316/316/CAM. 105
art. L2.....002	MOON 316/316/CAM. 105
art. P2.....004	[Extension nipples / Stutzen 1"] MOON ND 316/316/CAM. 105
art. L2.....004	MOON 316/316/CAM. 105

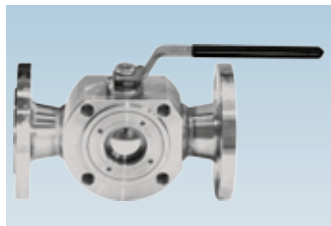

art. P2.....006	(Flange PN16) / (Flansch PN16) MOON ND 316/316/CAM. 105
art. L2.....006	MOON 316/316/CAM. 105

CARBON STEEL

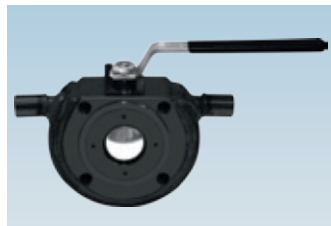

art. P7.....002	(Extension nipples / Stutzen 1/2") MOON ND 105/304/CAM. 105
art. L7.....002	MOON 105/304/CAM. 105
art. P7.....004	(Extension nipples / Stutzen 1") MOON ND 105/304/CAM. 105
art. L7.....004	MOON 105/304/CAM. 105



art. P7.....006	(Flange PN16) / (Flansch PN16) MOON ND 105/304/CAM. 105
art. L7.....006	MOON 105/304/CAM. 105

* (P= Moon ND / L= Moon standard)

MAIN STANDARD FEATURES:

- **CONSTRUCTION:** AISI316 - AISI304 - A105.
- **Heating jacket:** A105/A304.
- **JACKET CONNECTIONS:** FF gas or FLANGE PN16.
- For construction features of valves please refer to the relevant technical tables of the MOON VALVE.

GENERAL APPLICATIONS:

Applications: on-off valve where a steady temperature of the fluid is needed inside the valve by circulation of hot water, oil or other fluids inside the jacket mounted outside the valve body.

For special application please check the suitability of the valve for the process and the required corrosion resistancy using the relevant table.

SPECIAL EXECUTIONS:

- Ball drilling.
- **HEATING JACKET:** AISI304.
- **JACKET CONNECTIONS:** FF NPT ANSIB1.20.1 (taper threads).
- For further special requests please consult our technical/commercial service.

* (P= Moon ND / L= Moon standard)

ALLGEMEINE DATEN DER STANDARDAUSFÜHRUNG:

- **BAUFORM:** AISI316 - AISI304 - A105.
- **Heizmantel:** A105/A304.
- **MANTELANSCHLÜSSE:** FF Gas oder FLANSCH PN16.
- Für die baulichen Eigenschaften der Kugelhähne siehe jeweilige technische Tabellen des VENTILS MOON.

ALLGEMEINE ANWENDUNGEN:

ANWENDUNG als Absperrventil (ON-OFF) für: Einsätze, bei denen die konstante Temperaturbeibehaltung der Prozessflüssigkeit im Kugelhahn durch den Umlauf von Warmwasser, Öl oder anderem im Mantel, der direkt auf der Außenseite des Kugelhahns angebracht wird, nötig ist. Für Spezialanwendungen sind die Kompatibilität mit den Prozesseigenschaften sowie die Korrosionsbeständigkeit auch anhand der entsprechenden Tabelle zu prüfen.

SONDERAUSFÜHRUNGEN:

- Wuchtbohrung an der Kugel.
- **HEIZMANTEL:** AISI304.
- **MANTELANSCHLÜSSE:** F/F NPT ANSIB1.20.1 (konisches Gewinde).
- Für weitere Sonderanfragen bitte unsere Vertriebsabteilung kontaktieren.

CONSTRUCTION / AUFBAU

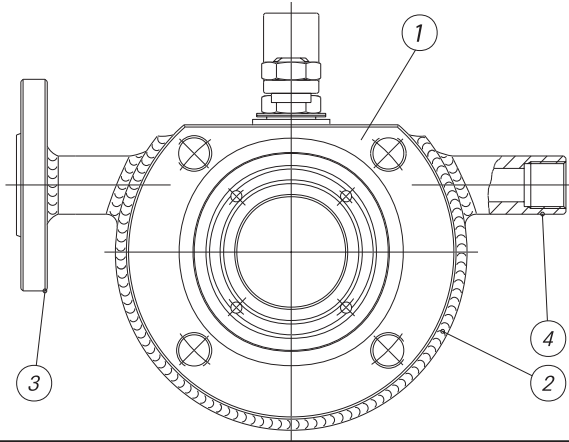

LIST OF COMPONENTS AND MATERIALS - TEILE- UND WERKSTOFFLISTE

REF. BEZ.	PART. TEIL	MATERIAL MATERIAL	MATERIAL MATERIAL	MATERIAL MATERIAL	QTY. MENGE
1	VALVE CONSTRUCTION / BAUFORM VENTIL	ASTM A105	AISI 304	AISI 316	1
2	JACKET / MANTEL	ASTM A105	ASTM A105	ASTM A105	1
3	FLANGES / FLANSCH	ASTM A105	ASTM A105	ASTM A105	2
4	THREADED END CONNECTIONS / MUFFEN	ASTM A105	ASTM A105	ASTM A105	2

Heating jacket only on valves from bar.

Mantel Nur auf Ventile aus Stange.

SECTION / QUERSCHNITT

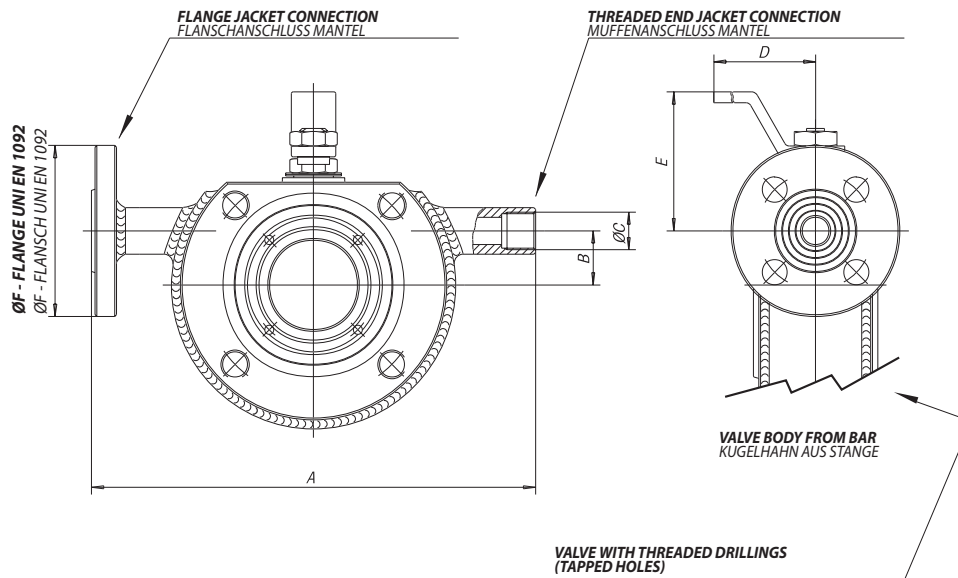

SIZE	A	B	ØC	D	E	ØF	Kv
DN15	170	0	G.1/2"	140	65	DN15	20
DN20	180	0	G.1/2"	140	70	DN15	60
DN25	190	0	G.1/2"	180	82	DN15	100
DN32	210	25	G.1/2"	180	85	DN15	130
DN40	230	30	G.1/2"	230	102	DN15	170
DN50	250	40	G.1/2"	230	110	DN15	280
DN65	270	45	G.1/2"	350	137,5	DN15	510
DN80	300	50	G.1/2"	350	150	DN15	770
DN100	340	70	G.1"	508	165	DN25	1200

PRESSURE/TEMPERATURE DIAGRAM - DRUCK- / TEMPERATURDIAGRAMM

REFER TO TABLES OF INDIVIDUAL CONSTRUCTIONS

SIEHE TABELLEN DER EINZELNEN BAULICHEN AUSFÜHRUNGEN

For Specifications about the Pressure-temperature Diagram and installation instructions, see page 410
Für Spezifizierungen bezüglich des Diagrammes Druck-Temperatur und Verwendungsvorschriften, siehe Seite 410

BREAKAWAY TORQUES in Nm / ANLAUFMOMENTE (BREAKAWAY) in Nm

PN - bar	DN size	15	20	25	32	40	50	65	80	100
0		4	7	10	16	25	35	55	75	150
16		4,8	8,5	11,3	19	28	39	59	84,5	168
25		5,2	9,1	12	20,5	29,5	41,5	62,5	92	180
40		6	10,5	13	22,5	31,5	44	67	99	195

The values in Nm may vary depending on the seat material, temperature and type of fluid.
For reliable operation of various types of actuators, in different working conditions, is recommended a safety factor of 1.5 (for PTFE).

Die Nm-Werte sind abhängig von dem Material der Sitzringe, der Temperatur und Art von Flüssigkeit.
Einen Sicherheitsfaktor von = 1,5 berücksichtigen (für PTFE).